

Morpeth UK



Morpeth UK

Reservoir storage capacity 1.4 mln m³

5 penstocks each 3000x3000 mm

1 fishpassage 1800x1800 mm



River flow control

KWT Tilting Weirs
Model **KSK** and **KKS**

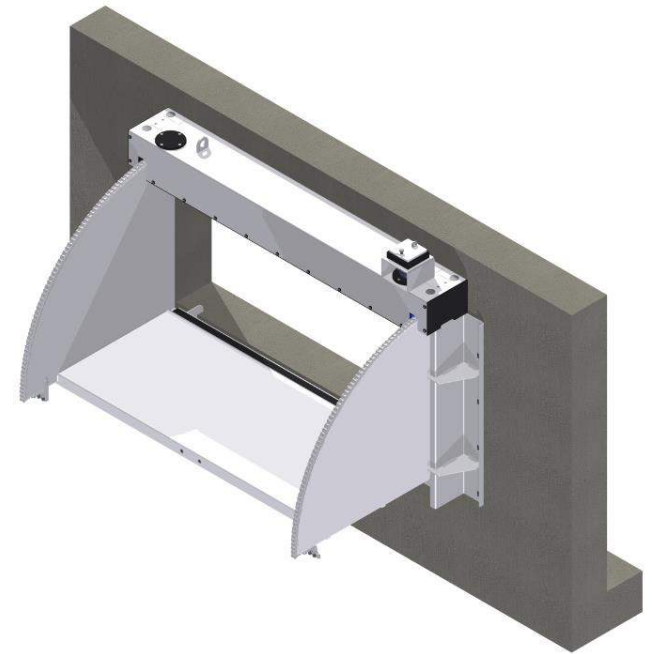
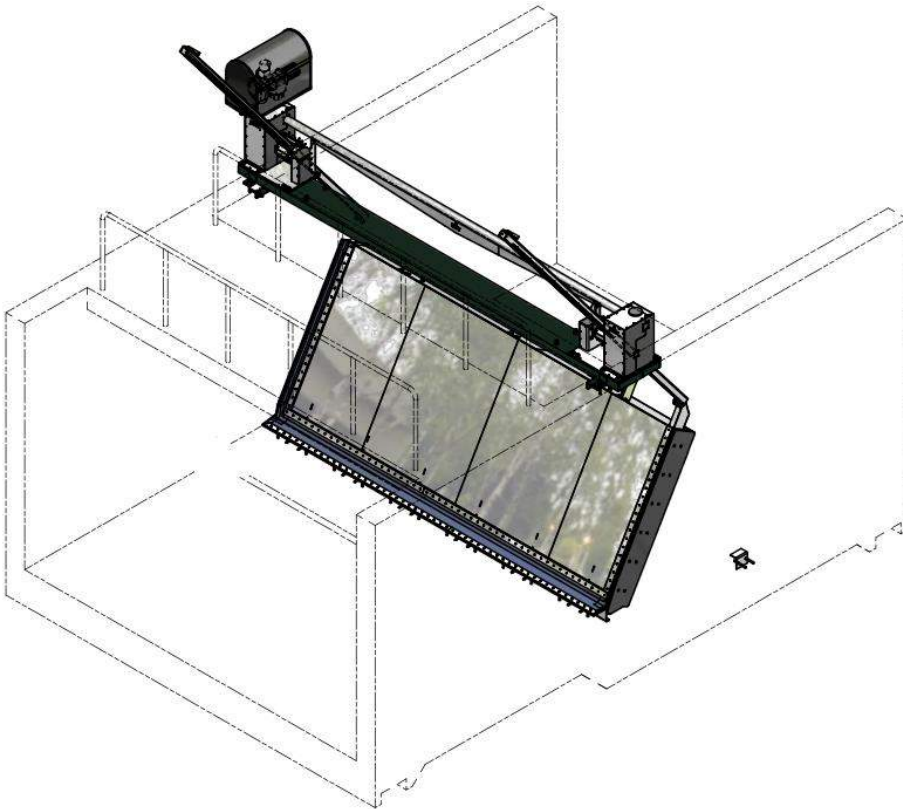

River flow control

KWT Tilting Weirs
Model **KSK** and **KKS**



Room for the River: NL



Replace dikes



Improve dikes



Additional channel



Dig out wash-land



Lower dams, piers, jetties

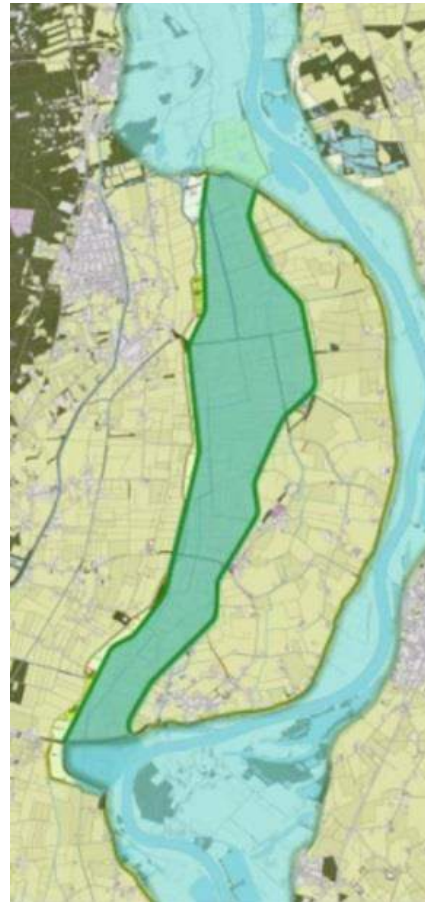

Dredge riverbed



Remove obstacles



Create water basins



Reclaim agricultural land

Catchment pumping stations



KWT bespoke **valves**,
penstocks and **stop logs**

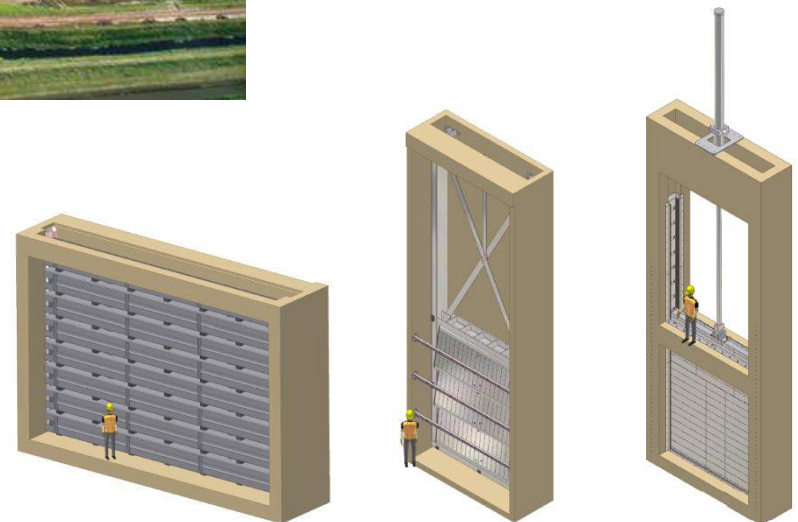

Upgrade drainage system

- Sewer pipes
- Combined Sewer systems
- Underground storage
- Drainage tunnel
- Add Sewage Treatment Capacity

KWT/HST Flap gates **RSK**
KWT/HST Flush gate **AWS**
KWT/HST Tunnel weir **ASA**

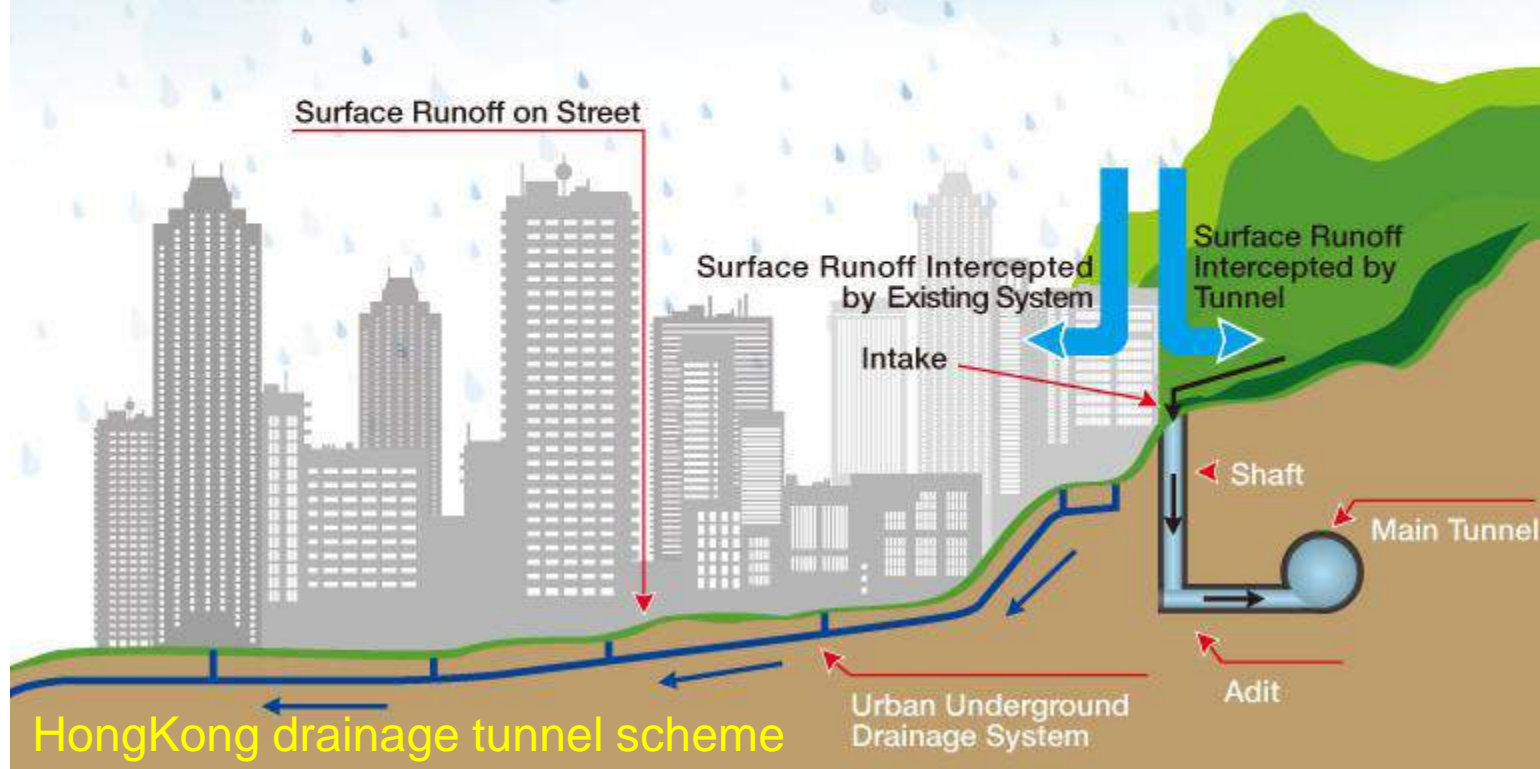

Upgrade drainage system

KWT/HST Flap gates **RSK**
KWT/HST Flush gate **AWS**
KWT/HST Tunnel weir **ASA**

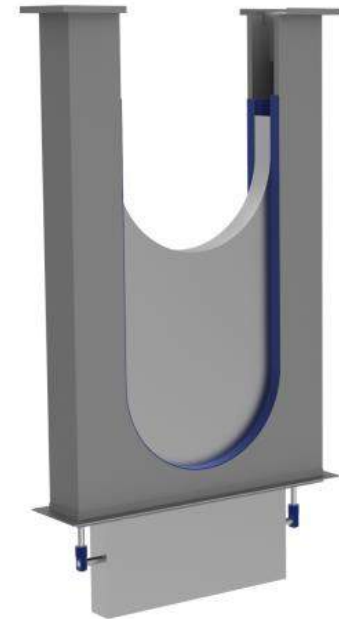

Upgrade drainage system



KWT/HST Flap gates **RSK**

KWT/HST Tunnel weir **ASA**

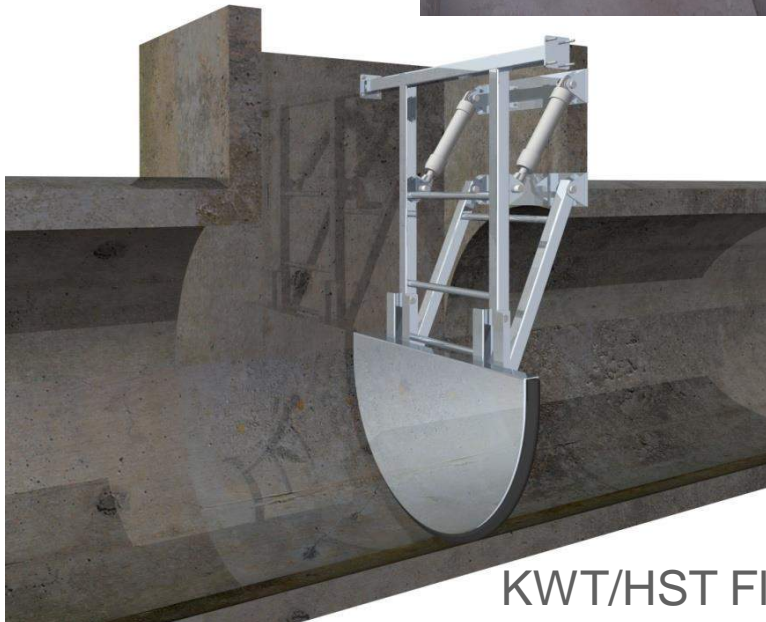
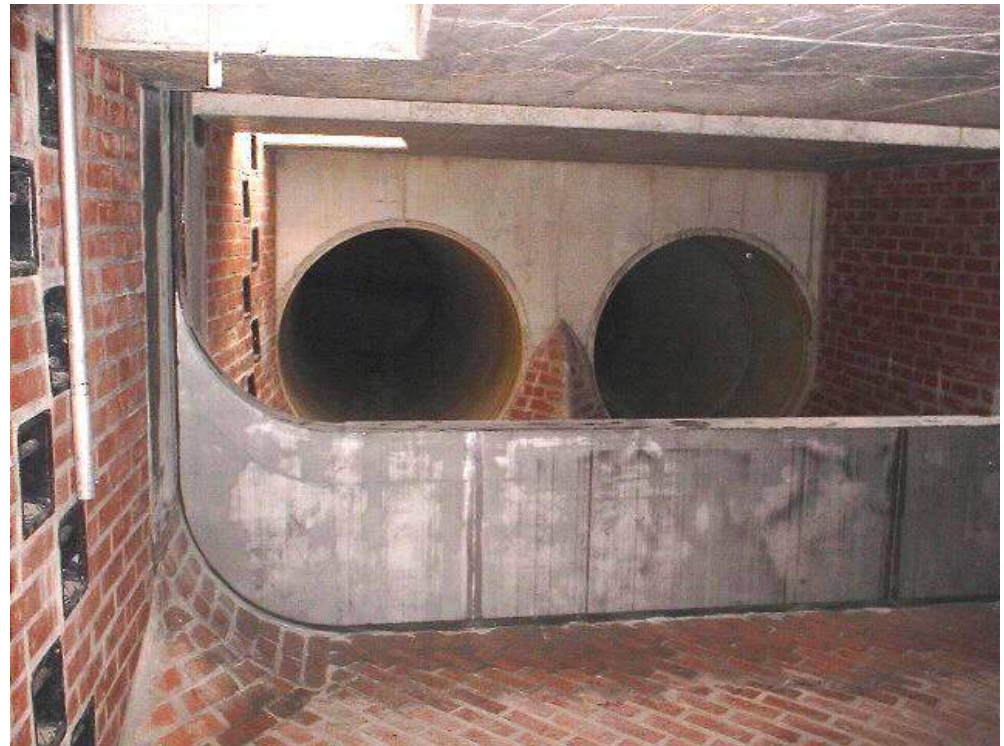

KWT/HST Flush gate **AWS**

Underground retention

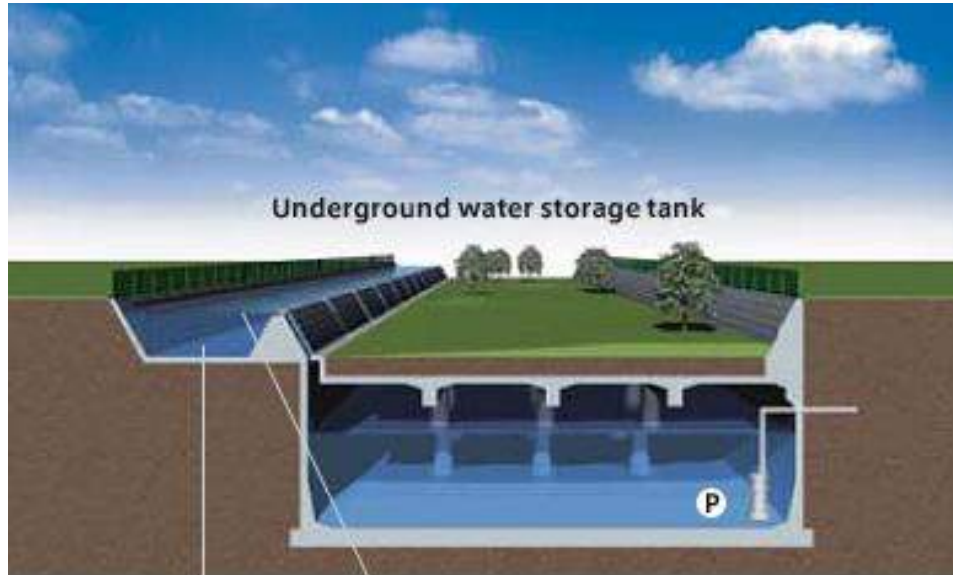

Source: Kawada Industries, Germany



Courtesy: Stadt Winterthur, CH)

Above ground retention

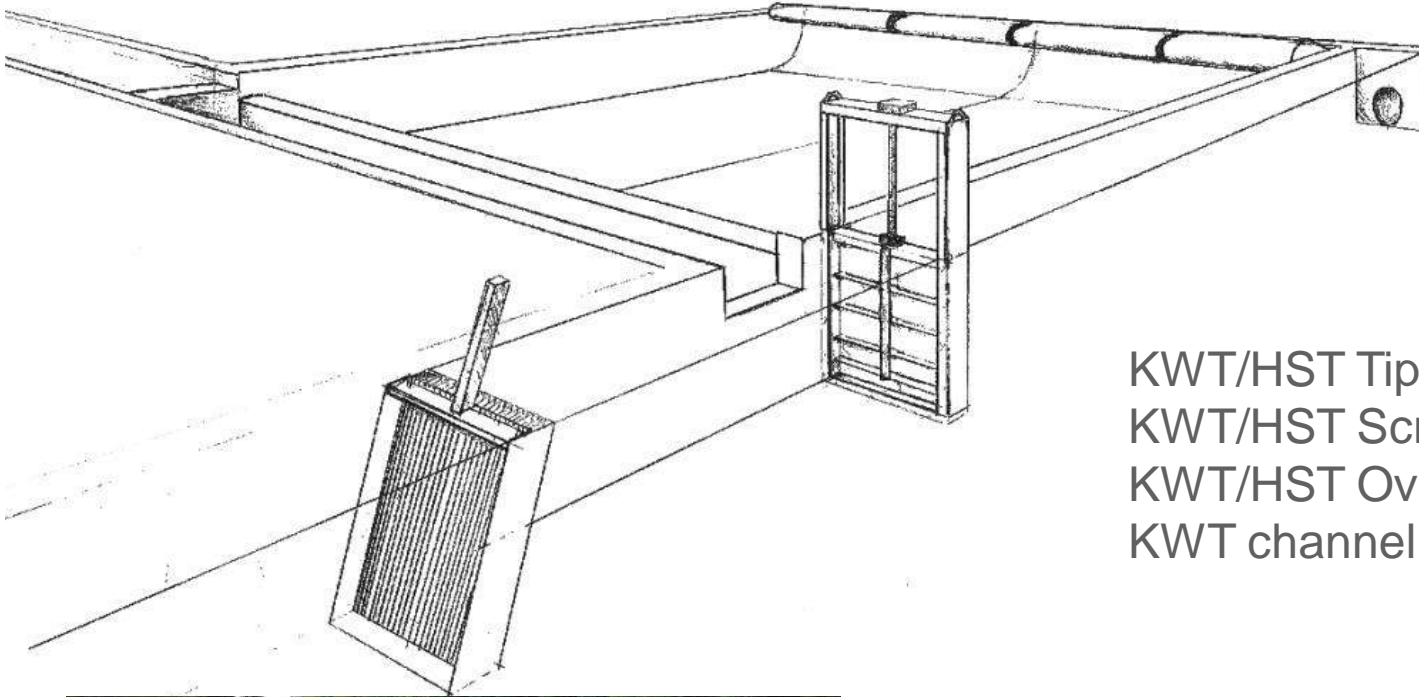

KWT/HST Tipping bucket **AWS**
KWT/HST Screen **VSR**
KWT/HST Overflow weir **ASK**
KWT channel penstock **KOAS**



Combined Sewer Overflow

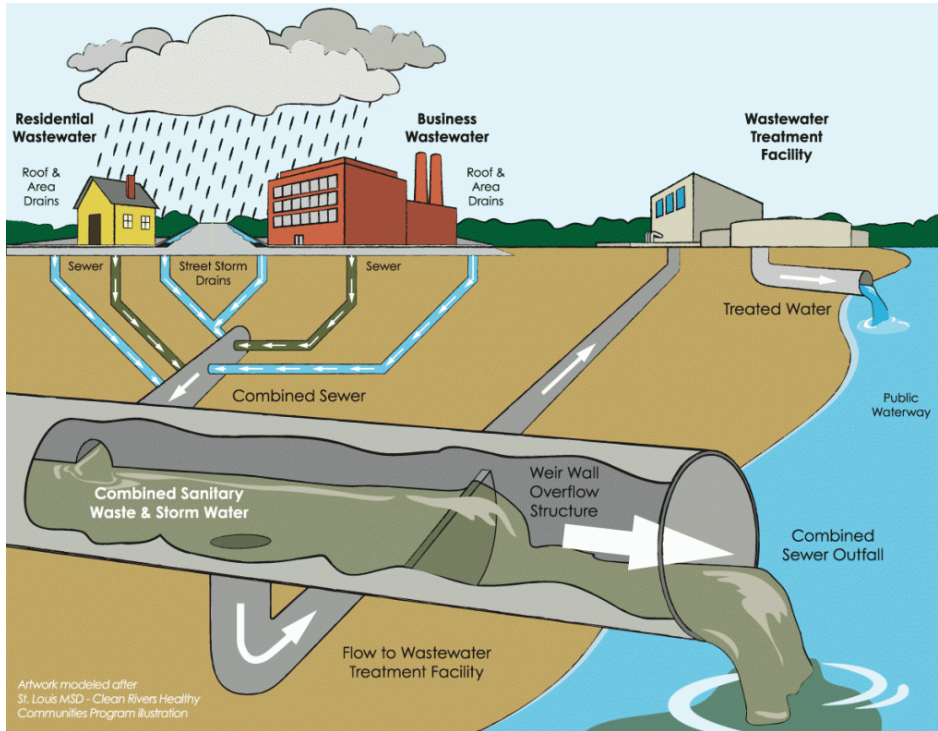

Source: CincinnatiUSA / GannettUSA

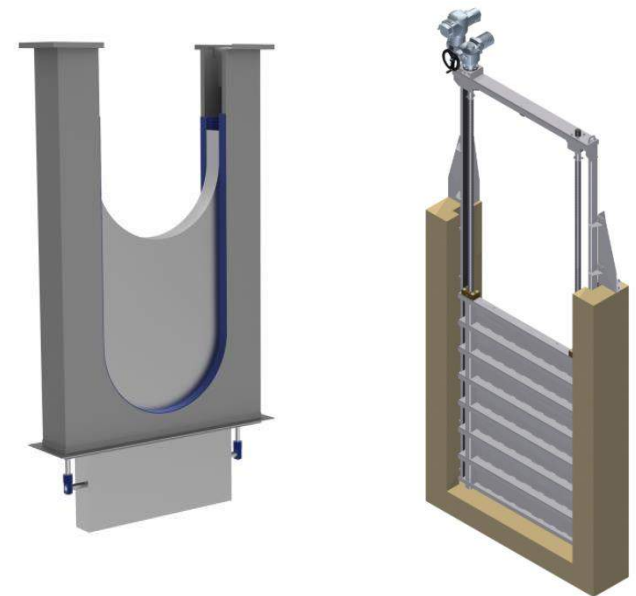

KWT/HST Tunnel weir **ASA**
KWT channel penstock **KOAS**

Imminent and imperative need:



Expand sewage treatment capacity



KWT sluice gates **KOAS**
KWT wall penstocks **KSA**
KWT overflow weirs **KOS**



Integrated Solution

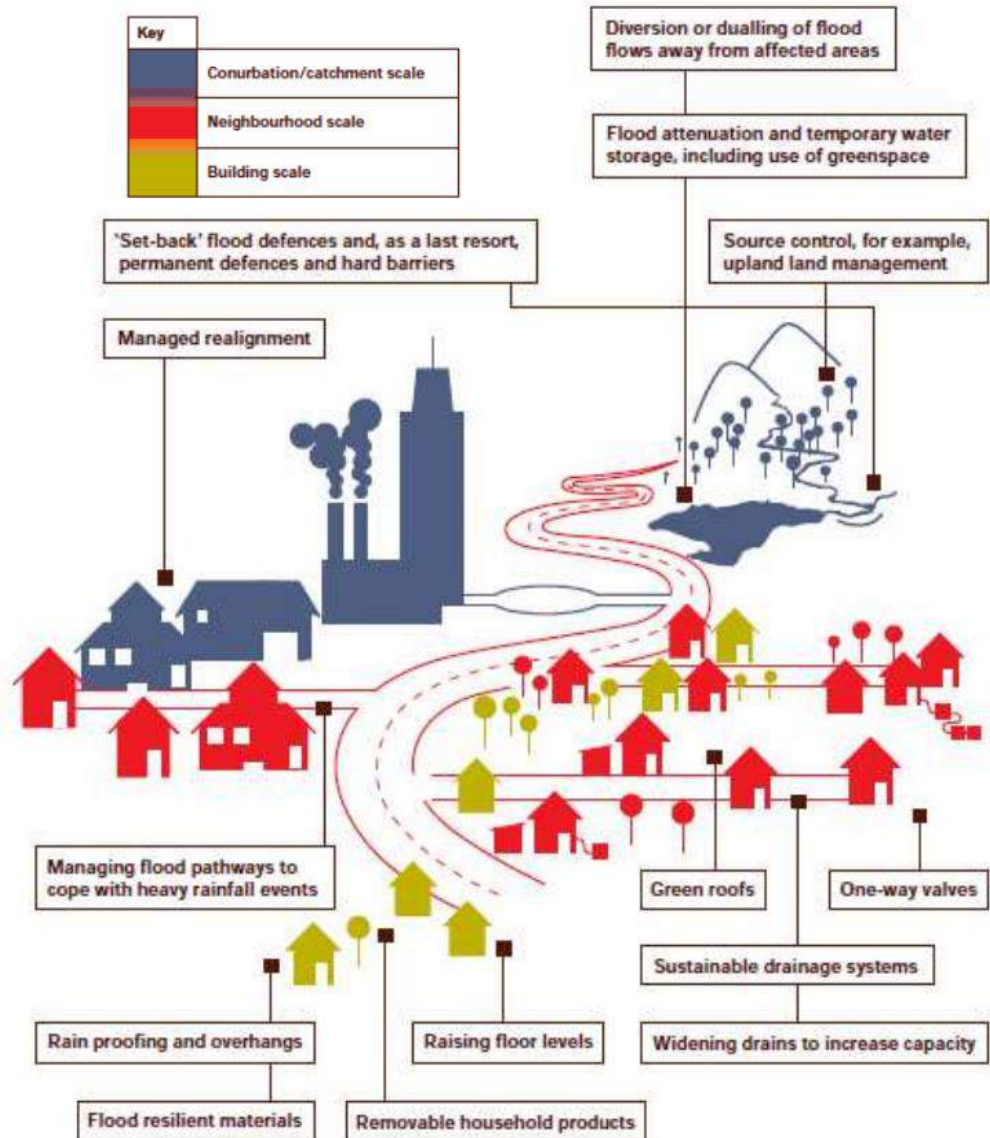



Welcome - messages

Contact us

Information request form



Home

KWT Corporate film

Flap Valves

Penstocks / Sluice gates

Tilting weirs

Fish Pass

Automatic water level control

Reference Projects

Sales Conditions

Distributor near you

KWT International: Leaders in innovative quantitative water management

KWT International is an operating company of KWT Group and a member of Bergschenhoek Groep. For over 50 years, Bergschenhoek Groep is a privately held group of companies active in the field of ventilation and air handling systems, central heating flue gas systems, and innovative solutions for water drainage-, econduct-, tunnel- and liquid storage systems. Bergschenhoek Groep employ over 350.

Founded in 1989, KWT International is the distribution branch for KWT's solutions in the field of global quantitative water management systems. Its focus is on systems for aquatic flow control used in surface water management (river flood control, eco-tourism, hydropower dams), as well as providing sluice gates, penstocks, gate valves, tilting weirs and non return valves to civil (STP and WWTP) contractors all over the globe.

In our home country, The Netherlands, KWT is the innovative leader when penstocks, tilting weirs and flap valves are involved. Thanks to its consistent product quality and creative designs. Although KWT has been exporting to a global community for many years, in 2005 a turnaround export strategy was formulated that required the creation of a global network. Today, KWT ships more than 60% of its volume to destinations outside its home market.

More than 35 international distributors and agents make sure that KWT is close to its clients, be it project consultants, civil contractors, water boards, municipalities, or ministries involved in water containment, transport or environment.

As a group, the KWT companies stand for daring and innovative product design, a worldwide strong and trusted image, and a proven product quality. For sewerage, pumping stations or flow regulation alike. All products are made from high grades of Stainless Steel 304L or 316L, often in combination with chemically inert High Density Poly Ethylene (HDPE). A product never leaves the factory if KWT QC is not satisfied.

KWT is certified against ISO 9001:2008



Thank you for your attention

J.M.R. den Hertog MSc
Director KWT Group
The Netherlands

Penstocks Brasil Comercial Ltda
www.penstock.com.br
Marcus Vinicius – Andre Oliveira

Summary

